



The product shown may differ from standard configuration.



ROADTIGER® DRIVER SEATS

Miles ahead in comfort and ergonomics



ROADTIGER® DRIVER SEATS

To ensure a better drive

A comfortable driver seat is not a superfluous luxury but a valuable investment in your performance, safety and health. With this conviction and our awareness of what you as a truck driver must accomplish every day, we at GRAMMER always have your back when it comes to ergonomic driver seats. TÜV Rheinland confirms that this has been impressively achieved: The top-of-the-line ROADTIGER® LUXURY and COMFORT models were awarded the LGA "Ergonomics Approved" certificate after comprehensive testing.

ROADTIGER® LUXURY

The ROADTIGER Luxury is a seat in a class of its own. It is upholstered in a luxury high-quality leather. With the active climate system the driver remains comfortable at all temperatures. A further special feature is the adjustable side support for the backrest and the seat cushion, ensuring that the seat can be set to individual driver's needs.

ROADTIGER® COMFORT

The ROADTIGER Comfort offers additional features to make the driver's journey much more pleasant. The passive climate system and seat heating ensure wellbeing in all temperatures. Thanks to the shoulder adjustment, the adjustable side support in the backrest and the 3-step seat belt height adjustment the seat can be made to fit the driver even more perfectly.

ROADTIGER® STANDARD

The ROADTIGER Standard features a pneumatic suspension system with automatic weight adjustment. It also comes with a fore/aft isolator, lumbar support and a finely adjustable backrest. The seat tilt adjustment and adjustable seat cushion depth ensure ergonomic comfort whilst sitting even in the entry level.



ROADTIGER® STANDARD

- Pneumatic suspension
- Pneumatic lumbar support
- Automatic weight adjustment
- Adjustable shock absorber
- Fore/aft isolator

ROADTIGER® COMFORT

- Pneumatic suspension
- Belt height adjustment
- Shoulder adjustment
- Tunnelside backrest release
- Adjustable side support for backrest and seat
- Pneumatic lumbar support
- Passive climate system
- Automatic weight adjustment
- Adjustable shock absorber
- Fore/aft isolator

ROADTIGER® LUXURY

- Pneumatic suspension
- Belt height adjustment
- Shoulder adjustment
- Tunnelside backrest release
- Adjustable side support for backrest and seat
- Pneumatic lumbar support
- Active climate system 2 steps
- Automatic weight adjustment
- Adjustable shock absorber
- Fore/aft isolator

Features	ROADTIGER® STANDARD	ROADTIGER® COMFORT	ROADTIGER® LUXURY
STANDARD FEATURES			
Pneumatic suspension	●	●	●
1 Shock absorber, adjustable in 4 steps	●	●	●
Suspension stroke, 55 mm	●	●	●
2 Height adjustment, 145 mm	●	●	●
Automatic weight adjustment 50-190 kg	●	●	●
3 Fore/aft adjustment	●	●	●
Mercedes	230 mm	230 mm	230 mm
MAN	220 mm	220 mm	220 mm
Scania	220 mm	220 mm	220 mm
DAF	220 mm	220 mm	220 mm
4 Quick down	●	●	●
5 Fore/aft isolator, 25 mm	●	●	●
6 Adjustable seat cushion angle	●	●	●
7 Integrated headrest	●	●	●
8 Adjustable backrest angle	●	●	●
9 Tunnel-side backrest release	●	●	●
10 Pneumatic shoulder adjustment	●	●	●
11 Pneumatic lumbar support	●	●	●
12 Adjust. side support, backrest	●	●	●
Adjust. side support, backrest and seat cushion	●	●	●
13 Adjustable seat cushion depth, 60 mm, 6 steps	●	●	●
14 Seat heating, 2 steps	●	●	●
Passive climate system	●	●	●
15 Active climate system, 2 steps	●	●	●
16 Integrated 3-point belt	●	●	●
17 Belt height adjustment, 60 mm, 3 steps	●	●	●
Belt buckle with contact switch	●	●	●
Seat belt pretensioner (DAF)	●	●	●
Upholstery fabric	●	●	●
Upholstery leather	●	●	●
OPTIONAL FEATURES			
18 Comfortable armrests, tiltable	○	○	○
Comfortable armrests, tiltable, covered in fabric	○	○	○
Comfortable armrests, tiltable, covered in leather	○	○	○
Seat occupancy detection	○	○	○

Measurements (installation dimensions)

● STANDARD FEATURES

○ OPTIONAL FEATURES

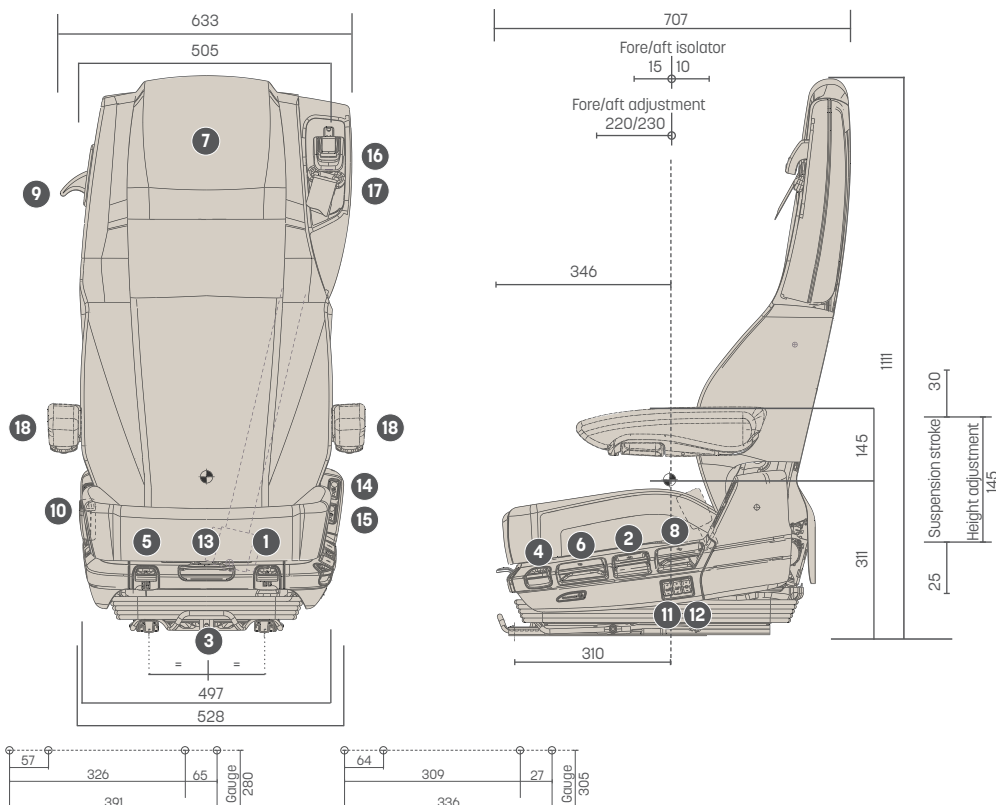

Different gauges available.

All measures in mm. Technical information subject to change, dimensions subject to variation.



Learn more
about ROADTIGER®
retrofit seats from
GRAMMER.
grammer.com

OVERVIEW OF ARTICLE NUMBERS

Article numbers	ROADTIGER® STANDARD	ROADTIGER® COMFORT	ROADTIGER® LUXURY
Usage (National Type Approval (Germany))			
Mercedes-Benz (screw-on dimension vehicle 280 mm)	Left:	Left:	Left:
Actros	1439931-A	1439933-A	1439935-A
Arocs	Right:	Right:	Right:
Antos	1439932-A	1439934-A	1439936-A
MAN (screw-on dimension vehicle 230 mm)	Left:	Left:	Left:
TGX, TGA	1439937-A	1439939-A	1439941-A
(TGS, TGM, TGL > 12 t on request)	Right:	Right:	Right:
	1439938-A	1439940-A	1439942-A
Adapter plate (screw-on dimension vehicle 230 mm on seat track gauge 305 mm)	1533226-A	1533226-A	1533226-A
Scania (screw-on dimension vehicle 230mm)	Left:	Left:	Left:
S- and R- Series	1439937-A	1439939-A	1439941-A
	Right:	Right:	Right:
	1439938-A	1439940-A	1439942-A
Adapter plate (screw-on dimension vehicle 230 mm on seat track gauge 305 mm)	1533226-A	1533226-A	1533226-A
DAF (screw-on dimension vehicle 305 mm)	Left:	Left:	Left:
XF	1401903-A	1401908-A	1401913-A
CF	Right:	Right:	Right:
	1401905-A	1401911-A	1401915-A

ROADTIGER® driver seats from GRAMMER are available for a wide range of different commercial vehicles models. Your GRAMMER sales partner will be happy to show you the retrofit seats suitable for your vehicle.